



# Wabash 971 RPS

## Rotary Position Sensor

Designed to operate in demanding environments where long life and high performance is required.

The Wabash 971 Rotary Position Sensor (RPS) uses high performance conductive polymer tracks and contact designs to achieve 2 percent independent linearity. Reliable and versatile, it is ideal for applications such as:

- Electric industrial vehicles
- Off-road steering and transmission
- Engine management and controls
- Recreational vehicles
- Agricultural equipment

The RPS can be supplied with options for electrical track length, resistance, flying leads, integral connector and actuator drive direction. Its rugged design can withstand:

- Temperature extremes
- Harsh environments
- Mechanical shock and vibration

Wabash generic sensors offer customers low cost options with minimal or little tooling investment.

Count on Wabash Technologies for sensing solutions that add performance and value to products. We serve customers with advanced design and engineering capabilities, flawless quality performance, flexible manufacturing and on-time delivery.



To learn more about how our products can help you, contact us at 260-355-4100 or visit [www.wabashtech.com](http://www.wabashtech.com)

**Wabash**  
TECHNOLOGIES

Committed to sensor advancement.



# The Wabash 971 RPS

## Rotary Position Sensor

### Technical Specifications

#### PHYSICAL

- Fully “sealed” robust package suitable for automotive, agricultural, marine and industrial environments
- High performance, compact potentiometric sensor
- Suitable for arduous engine management and closed loop control system feedback applications
- Through-hole actuation capability
- Integral connector or flying lead versions
- Actuator and mounting configuration options

#### ELECTRICAL

	Specifications
Track Resistance (Rt)	5K $\Omega$ $\pm$ 20% @ 20°C $\pm$ 10°C
Linearity (Independent)	$\pm$ 2%
Index Point	3% $\pm$ 2% @ -Low End Stop
Output Gradient	0.973%/° Max 0.873%/° Min
Power Rating	1 Watt @ 40°C Derated to Zero @ 135°C
Temperature Coefficient	$\pm$ 600ppm/°C
Insulation Resistance	1000M $\Omega$ Min 500V DC
Maximum Voltage	13.5V DC

#### MECHANICAL

	Specifications
Rotation	128° $\pm$ 2°
Spring Torque	Min Return - 6 Nmm Max Wind up - 120 Nmm
Mechanical End Stop Strength	680Nmm Min
Fixing Torque (M4 and Washer)	2Nm Maximum
Lead Wire Version 971 - 0002	16/0.2, 0.5 mm CSA 1.8 mm OD Pull Strength: 10 kg Max (all 3 wires)
Connector Version 971 - 0001	Connector to M47/2 AMP P/N 828748 - 3

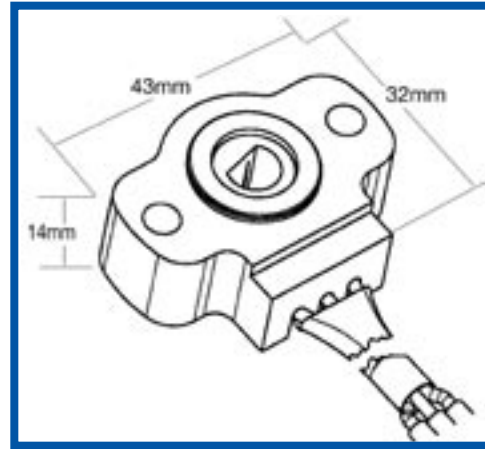

#### PERFORMANCE & ENVIRONMENTAL

	Specifications
Rotation Life (- 40° - +130°C)	5, 000, 000 Full Cycles 10, 800, 000 Dither Cycles (2°)
Functional Temperature Range	-40°C to +85°C Wire Version -40°C to +155°C Connector Version
Mechanical Shock (Handling)	1m Drop onto Concrete Floor
Mechanical Shock (Bump)	1000 40 g 11 ms Shocks (3 axis)
Vibration (Sinusoidal)	10 - 57 Hz @ 1 mm Displacement 57 - 100 Hz @ 10 g 100 - 500 Hz @ 27 g
Sealing	IP 5X (dust)
Pressure Wash	90 Bar 0.5-0.6 m 5-6 Seconds
Humidity	40°C 96% RH 504 Hours
Chemical Resistance	Screen Wash, Gearbox Oil Brake Fluid Dot 4 Isotane/Toluene (70/30) + 15% Methanol Engine Cleaning Agent, Engine Coolant Antigel Fluid, Electrolyte Density 1285 Kg/m3 (Sulphuric Acid H2SO4)