

- N°4 BORCHIE - ALTEZZA H=7.5  
FORI Ø6.5 - INTERASSE Ø336.9 ±0.1  
- N°4 BOSSES - HEIGHT H=7.5  
HOLES Ø6.5 - INTERAXLE Ø336.9 ±0.1

- N°4 GANCI PER PERNI Ø6  
INTERASSE Ø340.1 ±0.1  
- N°4 HOOKS Ø6  
INTERAXLE Ø340.1 ±0.1

SEDE PER ANELLO IN GOMMA  
RUBBER RING HOUSING

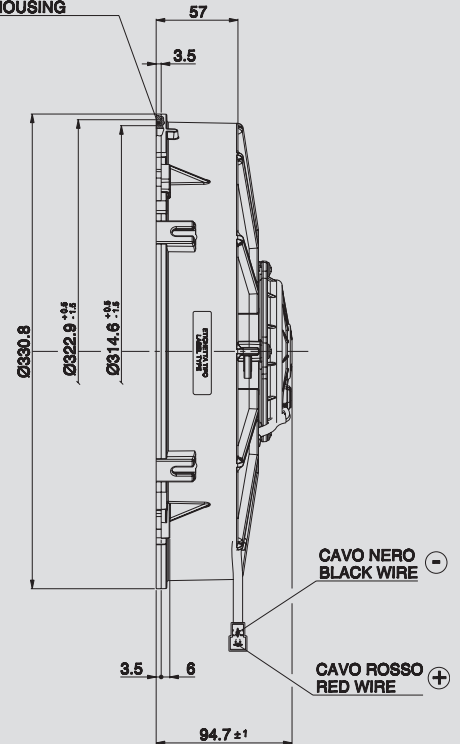
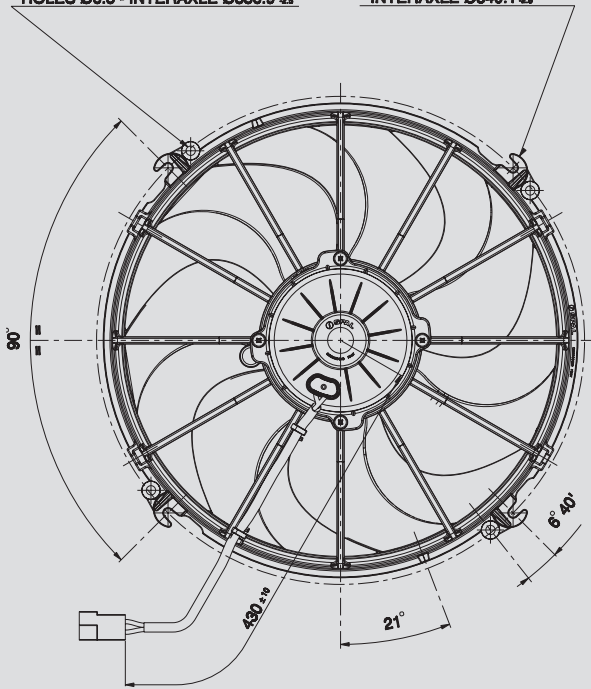

Ø 305 mm  
Ø 12"

Suggested mounting torque: 3(+1/-0) Nm with screw M5  
Weight 2,47 Kg. approx.

Coppia di serraggio consigliata: 3(+1/-0) Nm con vite M5  
Peso 2,47 Kg. circa

PRODUCT FEATURES  
CARATTERISTICHE PRODOTTO

suction / aspirante

blowing / soffiante

Waterproof motor, IP 68 <i>Motore chiuso, IP 68</i>	✓
Low noise / <i>Bassa rumorosità</i>	✓
Long life / <i>Lunga durata</i>	✓
VLL version* / <i>Versione VLL*</i>	✓
Waterproof connector <i>Connettori a tenuta stagna</i>	✓
Accessories: all the fixing kits <i>Accessori: tutti i kit di fissaggio</i>	✓

Static pressure <i>Pressione statica</i> mm H <sub>2</sub> O	suction / aspirante			blowing / soffiante			Static pressure <i>Pressione statica</i> inH <sub>2</sub> O
	Airflow <i>Portata</i> m <sup>3</sup> /h	Current input <i>Corrente assorbita</i> A	Airflow <i>Portata</i> CFM	Airflow <i>Portata</i> m <sup>3</sup> /h	Current input <i>Corrente assorbita</i> A	Airflow <i>Portata</i> CFM	
0	2460	12,8	1451	2650	15,8	1564	0
5	2170	14,2	1280	2390	16,4	1410	0,2
10	1860	15,0	1097	2070	17,0	1221	0,4
15	1410	15,3	832	1640	17,1	968	0,6
20	910	16,6	537	1090	17,4	643	0,8
25	520	17,8	307	620	18,0	366	1
30	280	19,4	165	320	18,9	189	1,2
35	100	21,6	59	70	20,7	41	1,4
40	0	22,5	0	0	21,0	0	1,6

\* for OEM applications only.  
\* per applicazioni OEM

✓ = Standard feature  
*Caratteristiche standard*  
✓ = Available upon request  
*Disponibile su richiesta*

Test voltage 13 V. d.c. - *Tensione di prova 13 V. c.c.*