

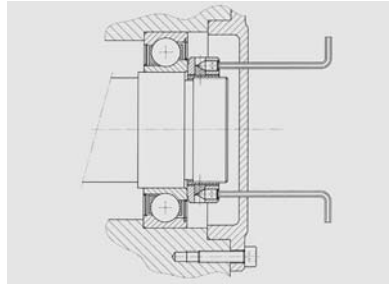

LFE NUT

2 SYMETRICAL CLAMPING SPRINGS BALANCED FRONT LOCKING



Back lash set up on an angular contact bearing

CHARACTERISTICS

- LFE nuts are used wherever radial clamping is not possible. They are therefore highly recommended for securing parts inside housings or deep chambers as well as for mounting bearings inside such places.
- Featuring 2 symmetrically opposed clamping springs at 180°, these nuts have two advantages when compared to LF nuts:
 - Increased balance allowing higher rotation speeds
 - Twice as much locking power for the same size
- The axial strength activated by turning the 2 Hc grub screws is exercised onto the threaded spring through 90° wedges.
- The resulting radial strength applies onto the threaded spring. The clamping pressure applied onto the threaded surface of the spring allows for a powerful locking.
- The contact surface perpendicular to the threaded side allows the adjusting and clamping of all types of bearings as well as other mechanical elements requiring very precise tolerances.
- In addition to the notches, the holes located on the front side allow an easy positioning of the nut by mean of a spanner wrench.

SPECIFICATIONS

- Material:**
High elastic limit steel
- Peripheral notches:**
4 at 90°
- IT 4
To ensure squareness and minimum run-out of the SFERO nuts and rings, all threading and contact face machining operations are performed in one setting.
- Screw:**
Hc type set-screw with cone tip 14.9
- Standard manufacturing:**
 - 4H class precision threading
 - right-hand thread
 - Fine-ground contact face
 - Marquing on the opposite side
 - Black oxide

OPTIONS

- Other versions are also available upon request:**
 - fine-ground threads
 - Left-hand thread
 - Other sizes
 - Other materials

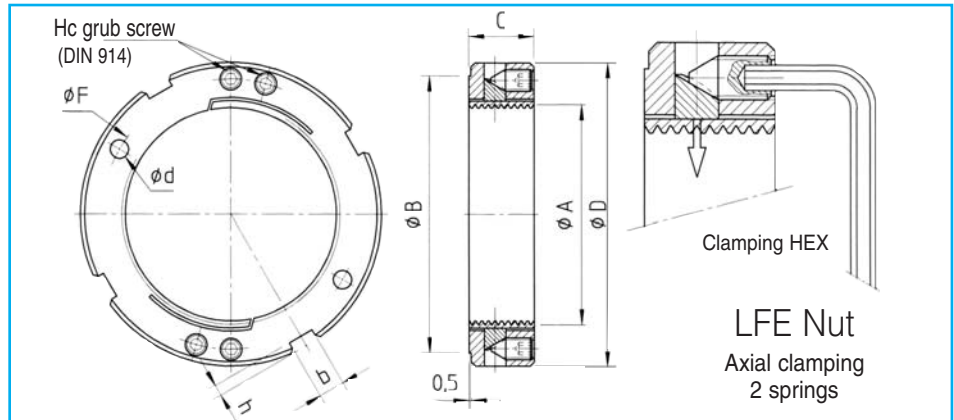

Type	Thread A	Ø D	Ø B	C	b x h	Ø F	Ø d	Hc grub screw	Unlocking Torque in Nm*	Max Axial load in Newton	Weight in Kg
LFE 7	22 x 1.50	39	34		4 x 2	30	3,2	4 x M 4	24	37 800	0,090
LFE 8	25 x 1.50	43	38			33			30	49 400	0,100
LFE 9	30 x 1.50	48	43			39			40	67 100	0,120
LFE 10	32 x 1.50	50	45	15	5 x 2	41			48	83 600	0,125
LFE 11	35 x 1.50	53	48			44			58	87 400	0,140
LFE 12	38 x 1.50	56	51			47			70	91 700	0,145
LFE 13	40 x 1.50	58	52			50			82	96 500	0,150
LFE 14	42 x 1.50	62	56			52		4	90	96 800	0,175
LFE 15	45 x 1.50	65	59		6 x 2,5	55	4,2	grub screws	110	108 800	0,185
LFE 16	50 x 1.50	69	63			59		M 5	140	132 200	0,190
LFE 17	52 x 1.50	72	66			62			170	137 600	0,215
LFE 18	55 x 2.00	75	68			65			210	193 000	0,23
LFE 19	60 x 2.00	80	73		7 x 3	72			260	211 000	0,33
LFE 20	65 x 2.00	85	78			76			320	238 600	0,35
LFE 21	70 x 2.00	90	82			81			400	257 300	0,36
LFE 22	75 x 2.00	95	87		8 x 3,5	86			440	298 100	0,39
LFE 23	80 x 2.00	105	97			93			480	318 300	0,55
LFE 24	85 x 2.00	110	102			98			500	338 600	0,57
LFE 25	90 x 2.00	115	107			104			530	366 700	0,60
LFE 26	95 x 2.00	120	111	20	10 x 4	107			590	387 400	0,63
LFE 27	100 x 2.00	125	117			114		4	650	408 100	0,65
LFE 28	105 x 2.00	130	119			118	5,2	grub screws	730	428 800	0,68
LFE 29	110 x 2.00	135	124			122		M 6	810	449 500	0,72
LFE 30	115 x 2.00	140	129		12 x 5	127			900	476 900	0,75
LFE 31	120 x 2.00	145	134			132			1000	508 600	0,78
LFE 32	125 x 2.00	150	139			137			1120	530 000	0,80
LFE 33	130 x 2.00	155	144			142			1270	559 200	0,85
LFE 34	135 x 2.00	165	152			150		4	1359	645 400	1,15
LFE 35	140 x 2.00	170	157	22	14 x 6	155	6,2	grub screws	2130	692 600	1,20
LFE 36	145 x 2.00	175	162			160		M 8	2130	717 600	1,25
LFE 37	150 x 2.00	180	167			165			2130	752 500	1,30

* Values obtained with Hc clamping screws:

- M 4 screw - clamping torque 2 Nm
- M 5 screw - clamping torque 3 Nm
- M 6 screw - clamping torque 7 Nm
- M 8 screw - clamping torque 17.5 Nm