

# FIG. AN7722-3A Grooved End Butterfly Valve



The Gruvlok® Figure AN7722-3A Grooved End Butterfly Valve is UL Listed and FM Approved as a system control valve. The valve is rated at 300 psi for steel pipe in the 2" to 10" sizes. The 2" through 10" sizes are agency rated for both indoor and outdoor service.

The valve is supplied with two internal switches. One is wired for supervisory service and the other is wired for use as an auxiliary switch. Both switches are rated for 11 amp at 125, 250 VAC and 0.5 amp at 125 VDC, 0.25 amp at 250 VDC. The switches and actuator internal spaces are protected from tampering.

The ductile iron valve body is encapsulated with a durable nylon coating to ensure long term service. The valve features double-seal disc design with resilient EPDM coating, and stems are 416 stainless steel. Detailed instructions for valve installation and switch wiring are included with each valve.

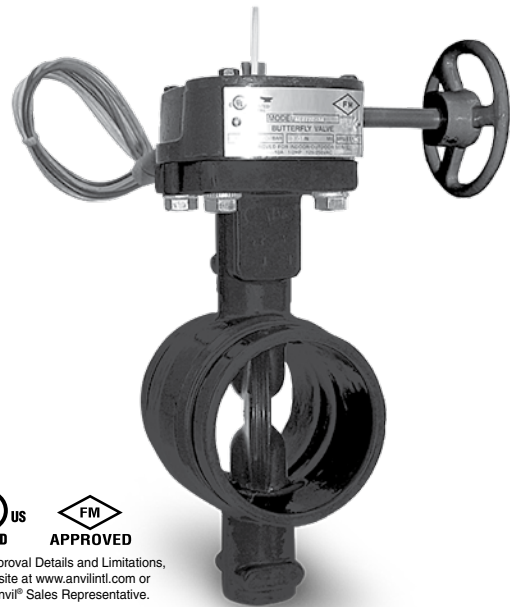

For Listings/Approval Details and Limitations, visit our website at [www.anvilint.com](http://www.anvilint.com) or contact an Anvil® Sales Representative.

## HEADLOSS EQUIVALENT LENGTH OF PIPE

Valve Size	Pipe O.D.	Equivalent Feet of Pipe* C=120		
		Sch. 10	Sch. 30	Sch. 40
In./mm	In./mm	Ft./m	Ft./m	Ft./m
2	2.375	5.8	-	4.7
50	60.3	1.8	-	1.4
2½	2.875	5.1	-	3.7
65	73.0	1.6	-	1.1
3	3.500	9.6	-	7.2
80	88.9	2.9	-	2.2
4	4.500	7.5	-	5.7
100	114.3	2.3	-	1.7
5	5.563	7.0	-	5.6
125	141.3	2.1	-	1.7
6	6.625	6.1	-	4.8
150	168.3	1.9	-	1.5
8	8.625	6.3	5.7	5.3
200	219.1	1.9	1.7	1.6
10	10.750	11.3	10.2	9.6
250	273.1	3.4	3.1	2.9

\* The equivalent feet of pipe is based on the Hazen and Williams formula and the flow rates typically used with each size valve.

## PRESSURE DROP (PSI) VS. (GPM)

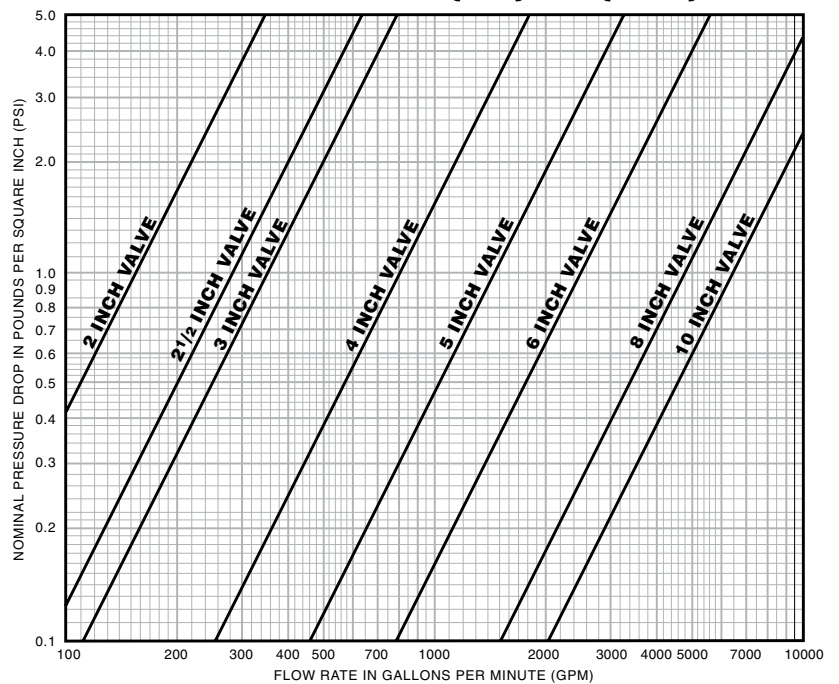

### PROJECT INFORMATION

### APPROVAL STAMP

<b>Project:</b>	<input type="checkbox"/> Approved
<b>Address:</b>	<input type="checkbox"/> Approved as noted
<b>Contractor:</b>	<input type="checkbox"/> Not approved
<b>Engineer:</b>	<b>Remarks:</b>
<b>Submittal Date:</b>	
<b>Notes 1:</b>	
<b>Notes 2:</b>	

# FIG. AN7722-3A Grooved End Butterfly Valve

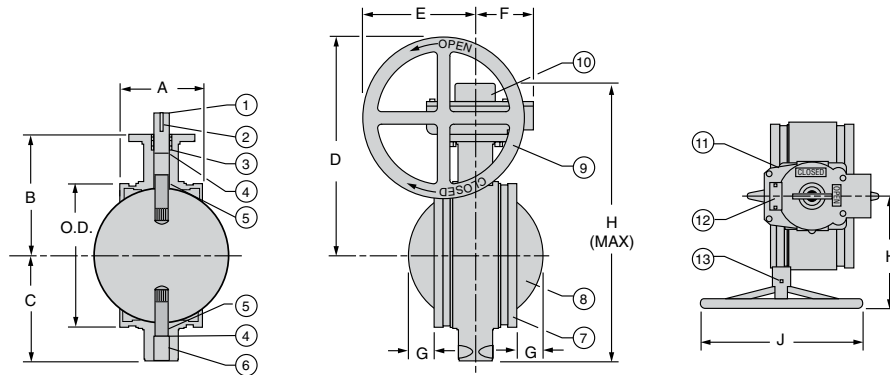

**FIGURE AN7722-3A UL/ULC/FM BUTTERFLY VALVE**

Valve Size	Pipe O.D.	Valve Dimensions									Approx. Wt. Ea.
		A	B	C	D	E	F	G	H	J	
2	2.375	3.19	2.97	3.87	6.17	4.18	2.25	—	4	3	19
50	60.3	81	75	98	157	106	57	—	102	76	9
2½	2.875	3.81	3.18	4.38	6.68	4.18	2.25	—	4	3	20
65	73.0	97	81	111	170	106	57	—	102	76	9
3	3.500	3.81	3.80	4.62	6.92	4.18	2.25	—	4	3	22
80	88.9	97	97	117	176	106	57	—	102	76	10
4	4.500	4.62	4.27	5.38	9.98	5.10	3.5	—	5	6	26
100	114.3	117	108	137	253	130	89	—	127	152	11.8
5	5.563	5.81	4.98	5.88	10.48	5.10	3.5	—	5	6	29
125	141.3	148	126	149	266	130	89	—	127	152	13.2
6	6.625	5.81	5.47	6.37	10.97	5.10	3.5	0.13	5	6	30
150	168.3	148	139	162	279	130	89	3	127	152	13.6
8	8.625	5.25	6.92	7.75	15.40	9.54	4	1.36	7.89	12	52
200	219.1	133	176	197	391	242	102	35	200	305	23.6
10	10.750	6.25	7.99	9.00	16.65	9.54	4	1.84	7.89	12	75
250	273.1	159	203	229	423	242	102	47	200	305	34.1

## MATERIAL SPECIFICATIONS

- UPPER STEM:** Stainless Steel, ASTM A-582, Type 416
- STEM SHEAR PIN:** for 2" thru 6" valves.  
**STEM SHEAR KEY:** for 8" and 10" valves.
- UPPER BUSHING:** Sintered Bronze (8" and 10" valves only)
- "O" RING:** Nitrile
- LOWER BUSHING:** Sintered Bronze (8" and 10" valves only)
- LOWER STEM:** Stainless Steel, ASTM A-582, Type 416
- BODY:** Ductile Iron ASTM A-536 with Nylon Coating
- DISC:** Ductile Iron ASTM A-536 with EPDM Encapsulation
- HANDWHEEL:** Ductile Iron
- INDICATOR FLAG:** Steel
- GEAR OPERATOR:** Ductile Iron and Steel
- NAMEPLATE:** Stainless Steel
- HANDWHEEL SHEAR PIN:** Carbon Steel AISI 1070

## CV VALUES

Valve Size	Pipe O.D.	Disc Position							
		25°	30°	40°	50°	60°	70°	80°	90°
2	2.375	4	7	19	44	48	80	111	158
50	60.3	0.3	0.5	1.3	3.0	3.3	5.5	7.7	10.9
2½	2.875	9	14	34	78	84	142	196	280
65	73.0	0.6	1.0	2.3	5.4	5.8	9.8	13.5	19.3
3	3.500	14	20	50	112	128	215	285	400
80	88.9	1.0	1.4	3.4	7.7	8.8	14.8	19.7	27.6
4	4.500	29	41	100	239	250	420	582	826
100	114.3	2.0	2.8	6.9	16.5	17.2	29.0	40.1	57.0
5	5.563	62	76	182	415	445	780	1,100	1,480
125	141.3	4.3	5.2	12.5	28.6	30.7	53.8	75.8	102.0
6	6.625	96	141	325	755	809	1,370	1,920	2,678
150	168.3	6.6	9.7	22.4	52.1	55.8	94.5	132.4	184.6
8	8.625	172	252	592	1,365	1,460	2,430	3,410	4,819
200	219.1	11.9	17.4	40.8	94.1	100.7	167.5	235.1	332.3
10	10.750	230	328	792	1,825	1,962	3,260	4,590	6,431
250	273.1	15.9	22.6	54.6	125.8	135.3	224.8	316.5	443.4



## ACTUATOR WIRING

### SUPERVISORY SWITCH

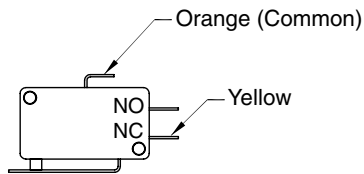

Normally Open (NO): Not Wired  
 Normally Closed (NC): (2) Yellow  
 Common: (2) Orange

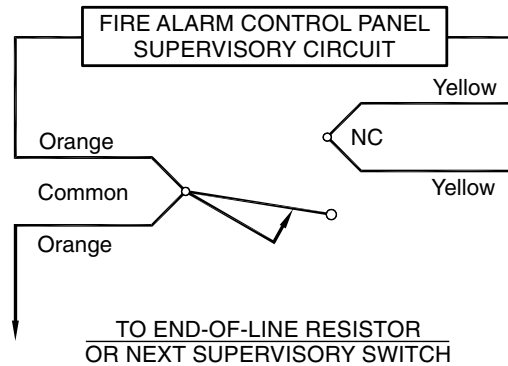

**Notes:**

1. Single Pole Double Throw Switch wired "Normally Closed"; supplied with Dual Wire leads.
2. Switch Schematic shown with Valve in the Full Open Position and Switch depressed.

### AUXILIARY SWITCH

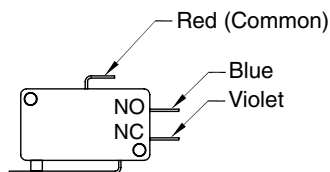

Normally Open (NO): Blue  
 Normally Closed (NC): Violet  
 Common: Red

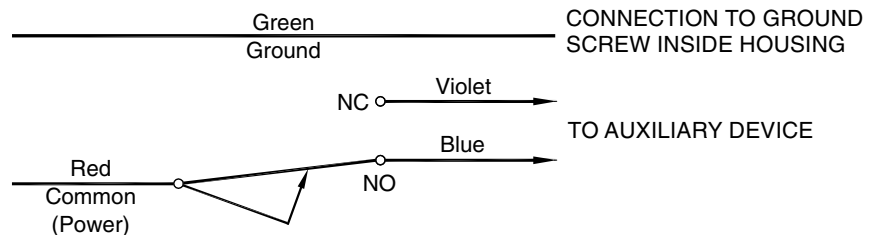

**Notes:**

1. Single Pole Double Throw Switch wired "Normally Closed"; supplied with Single Wire leads.
2. Switch Schematic shown with Valve in the Full Open Position and Switch depressed.

**Notes:**

- Single Pole Double Throw Switch; Pre-Wired
- Wire Leads: 18 AWG, 10" (254 mm) Long
- Rated to 11A @ 125, 250 VAC and 0.5A @ 125 VDC, 0.25A @ 250 VDC
- Operating Temperature: -40°C (-40°F) to 180°F (82°C)